



Job _____ Item No. _____

Electric Countertop Griddle

Snap-Action/Steel Plate 124T 136T 148T 160T 172T

Snap-Action/Chrome Plate 124TC 136TC 148TC 160TC 172TC

Solid State/Steel Plate 124S 136S 148S 160S 172S

Solid State/Chrome Plate 124SC 136SC 148SC 160SC 172SC

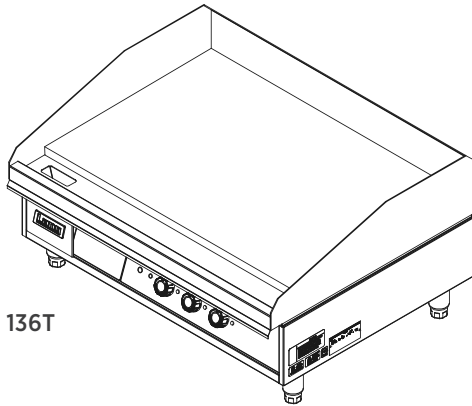

136T

DESCRIPTION

Lang electric griddles are designed to be reliable, efficient, and accurate. Each twelve [12] inch (305 mm) section has its own independent temperature control and the griddle surface is one [1] inch (25 mm) thick, providing even cooking of multiple different products at the same time.

SPECIFICATIONS

The Lang electric countertop griddle will be constructed in the U.S.A. with a corrosion-resistant stainless steel base. The griddle plate will be one [1] inch (25 mm) thick and come with either a chrome or polished steel surface. The incoloy sheathed heating elements will allow control of each twelve [12] inch (305 mm) section. The temperature will be controlled by either Selectronic™ solid state system or Accu-Temp™ snap-action thermostats.

There will be one temperature control for each twelve [12] inch (305 mm) section. The power will be rated at 6 kW per twelve [12] inch (305 mm) of griddle width. The units will be shipped ready to hard-wire to a 208V/3-phase connection. They will be able to be field-converted to 208/1- phase, 240V/1- or 3-phase. A 480V/ 3-phase* is available, and will be shipped ready to hard-wire. 60-inch and 72-inch models will require two [2] connections.

*Specify voltage when ordering.

WARRANTY

These units come with a two [2] year warranty for parts and labor.

FEATURES

- One [1] inch (25 mm) thick griddle surface
- 6 kW of power per twelve [12] inch section of griddle
- 5.5-inch (140 mm) rear and side splash guard and a 3.5-inch (89 mm) by one [1] inch (25 mm) grease trough for easy cleanup
- Standard Accu-Temp™ controls use snap-action thermostats and operate between 200° F (93° C) and 550° F (288° C)
- Optional Selectronic™ controls use a solid-state system which reacts to a temperature change as small as 1°F and operate between 175° F (79° C) and 450° F (232° C)
- Both types of thermostat allow independent control of each twelve [12] inch (305 mm) section of griddle

OPTIONS & ACCESSORIES

- Polished steel or chrome griddle plate
- Snap-action thermostats or solid state temperature control
- Contact or radiant clamshell hood—up to one per twelve [12] inch (305mm) of griddle surface
- Custom grooved plate, 12 or 24 inches (305 or 610 mm) from either side
- Steel stand with legs or casters

CERTIFICATIONS





Electric Countertop Griddle

Snap-Action/Steel Plate □124T □136T □148T □160T □172T

Snap-Action/Chrome Plate □124TC □136TC □148TC □160TC □172TC

Solid State/Steel Plate □124S □136S □148S □160S □172S

Solid State/Chrome Plate □124SC □136SC □148SC □160SC □172SC

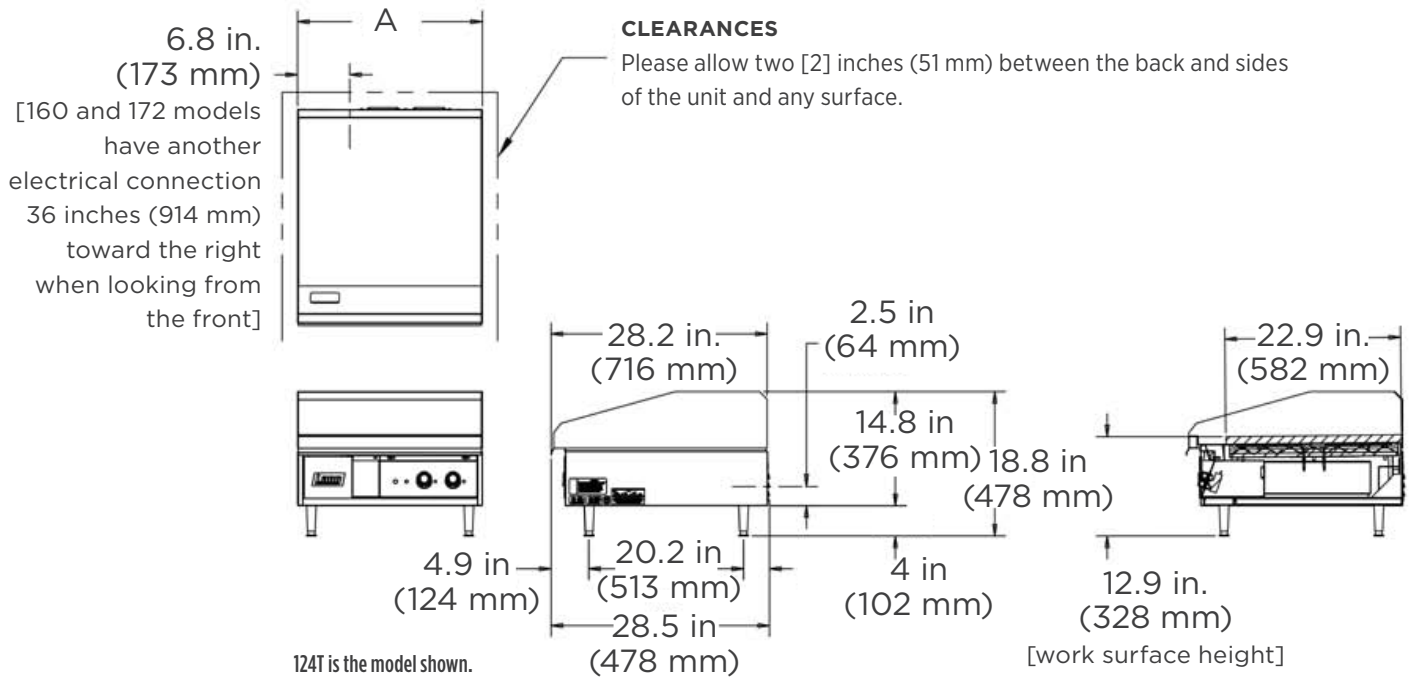

MODEL	HEIGHT	WIDTH [A]	DEPTH	VOLTAGE	kW	1Φ	3Φ L1	3Φ L2	3Φ L3	APPROX. SHIP WEIGHT	APPROX. WEIGHT INSTALLED
124	18.8 in. (478 mm)	24.1 in. (612 mm)	28.5 in. (724 mm)	208	12	57.7	50	28.9	28.9	300 lb. (136 kg)	228 lb. (103 kg)
				240		43.3	25	25			
				480		N/A	22	13	13		
136	18.8 in. (478 mm)	36.1 in. (914 mm)	28.5 in. (724 mm)	208	18	86.5	50	50	50	409 lb. (186 kg)	331 lb. (150 kg)
				240		75	43.3	43.3	43.3		
				480		N/A	22	22	22		
148	18.8 in. (478 mm)	48 in. (1.22 m)	28.5 in. (724 mm)	208	24	115.2	76	76	50	520 lb. (236 kg)	428 lb. (194 kg)
				240		100	66.1	66.1	43.3		
				480		N/A	33	33	22		
160 ¹	18.8 in. (478 mm)	60 in. (1.52 m)	28.5 in. (724 mm)	208	30	C1	same as 136			656 lb. (298 kg)	556 lb. (252 kg)
				240		C2	same as 124				
172 ¹	18.8 in. (478 mm)	72 in. (1.83 m)	28.5 in. (724 mm)	208	36	C1	same as 136			787 lb. (357 kg)	642 lb. (291 kg)
				240		C2	same as 136				
				480							

¹ Requires two electrical connections, noted as C1 for connection one [1] and C2 as connection two [2]. These models are not CSA / ETL certified.

Due to periodic changes in designs, methods, procedures, policies and regulations, the specifications contained in this sheet are subject to change without notice. While Star Manufacturing exercises good faith efforts to provide information that is accurate, we are not responsible for errors or omissions in information provided or conclusions reached as a result of using the specifications. By using the information provided, the user assumes all risks in connection with such use.



LANG MANUFACTURING • www.langworld.com
265 Hobson Street • Smithville, Tennessee 37166
Telephone 314 678 6315 • Fax 314 781 3636

Printed in the U.S.A. • 2M-Z21304 • Rev C • 06.2020
Please refer to the owner's manual for information regarding installation or use.