

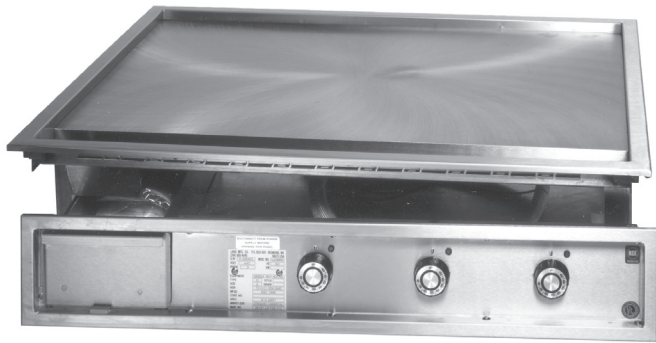

MARINE MODEL TDIG [136, 148, 172]

Drop-In Electric Griddles



Model 136TDIG

MARINE MODEL DESCRIPTION

Griddle shall be a LANG Manufacturing Marine Model 1_ [Specify width: 36", 48" or 72"]TDIG, with: thermostat controls for each 12" of griddle width; 6-kW per foot of Incoloy sheathed heating elements, pressure clamped to plate bottom; 3/4" thick polished cooking surface; flanged flush-mount griddle surface module and recessed control panel module for easy installation in countertop.

SIZING AND PERFORMANCE GUIDE

MODEL #	SURFACE AREA	CONTROLS	kW INPUT
136TDIG	828 sq. in.	3	18 kW
148TDIG	1104 sq. in.	4	24 kW
172TDIG	1656 sq. in.	6	18/18 kW

MARINE CONSTRUCTION FEATURES

- 3/4" thick precision machined, polished steel cooking surface
- Full parameter stainless steel top mounting flange
- Full front 3 1/2" wide x 1" deep stainless steel grease trough
- 8 quart capacity grease drawer w/marine latch & fully enclosed, easily removable sleeve [two on 72" model]
- Fully enclosed control compartment
- Separate, insulated stainless steel griddle and control modules

CONTROL PACKAGE

- Independent temperature control every 12"
- Heat on pilot lights for each control

CONSTRUCTION FEATURES

- Thick griddle plate reduces hot & cold spots and retains heat
- Highly polished, recessed surface and continuously welded mounting flange speeds cleanup
- Heating elements incoloy sheathed for long life
- Elements are pressure clamped to bottom of griddle for an even heat
- Recessed control panel protects control knobs
- Accurate temperature control between 175° and 450°

STANDARD PRODUCT WARRANTY

- One year, parts & labor [Labor in U.S. only]



MARINE INSTALLATION REQUIREMENTS

- ❑ 440V or 480V, 3-phase power connection
- ❑ Two electric connections required for 72" unit
- ❑ Installation in approved cabinet or galley work center [Provided by others]

MARINE OPTIONS & ACCESSORIES

- ❑ See below for rough openings required for griddle and control panel module
- ❑ Consult marine codes for installation requirements

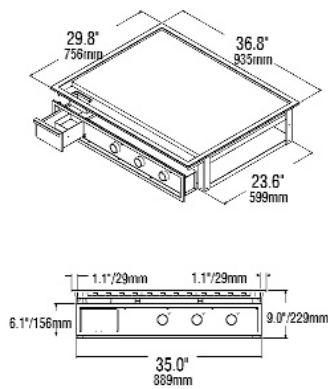

3D FRONT VIEW 136TDIG

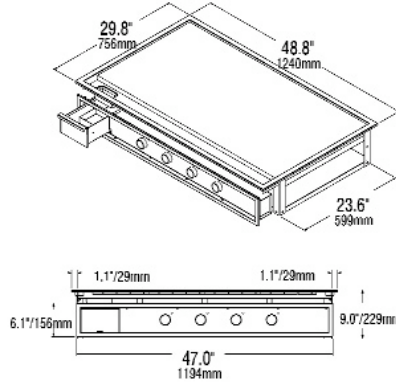

3D FRONT VIEW 148TDIG

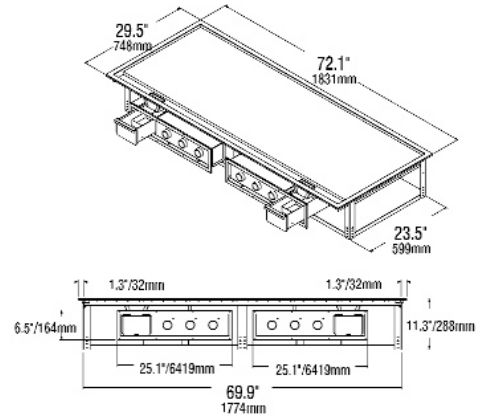

3D FRONT VIEW 172TDIG

Model #	Top-Rough Opening		Controls Opening		Clearance from Surface	Weight		Freight Class	Volts AC [Hz]	Watts [kW]	3-Phase AMPS	1-Phase AMPS
	Width	Depth	Width	Depth		Actual	Ship					
136TDIG	36.8" 935mm	29.8" 756mm	6.1" 156mm	35.0" 899mm	Sides: 2" Back: 2"	295lbs. 120 kg	345lbs. 186 kg	85	208 - 50/60 240 - 50/60 440 - 50/60 480 - 50/60	18.0	50.0	86.5
											43.3	75.5
											23.6	n/a
											21.7	n/a
148TDIG	48.8" 1240mm	29.8" 756mm	6.1" 156mm	47.0" 1194mm	Sides: 2" Back: 2"	400lbs. 167 kg	450lbs. 239 kg	85	208 - 50/60 240 - 50/60 440 - 50/60 480 - 50/60	24.0	75.0	115.2
											65.0	100.0
											36.8	n/a
											32.5	n/a
172TDIG	72.1" 1831mm	29.5" 748mm	6.5"* 164mm	25.2" 641mm	Sides: 2" Back: 2"	650 lbs. 295 kg	700lbs. 318 kg	85	208 - 50/60 240 - 50/60 440 - 50/60 480 - 50/60	36.0 [18/18]**	50/50	86.5/86.5
											43.3/43.3	75/75
											23.6/23.6	n/a
											21.7/21.7	n/a

*Two openings required in the Controls Opening table for the 172TDIG model. **Two connections

CAD SYMBOLS & PRICING

