



Item No. _____

Project _____

Quantity _____

Electric, Full-Size/Extra-Deep Convection Oven

Model: ECOD-[AP/S/PT]1



Model ECOD-PT2 shown, with optional 27" stand.

PAN CAPACITY GUIDE

Pan Type	Rack Positions	Optimum
18" X 26" Full-Sheet*	10 or 11**	5
12" X 20" Hotel***	-	10

* Loaded lengthwise or sideways

** AP & SII = 10; PT = 11

*** 2-1/2" deep pans

SHORT/BID SPECIFICATION

Convection Oven shall be a **LANG Manufacturing Model ECOD-**____ with [AP=Accu-Plus, S=Selectronic II, PT=Platinum] Control Package, an 11.66-kW electric heated 5-pan full-size unit, with: simultaneous-opening heavy duty doors; all stainless steel exterior and extra deep porcelainized steel cooking compartment; powerful rear mounted blower with two speed motor and pulse control; compartment inspection lights and five pan racks standard; plus a "life-time" warranty on doors. Includes all the features listed and options/accessories checked:

STANDARD PRODUCT WARRANTY

- Three year, parts & labor
- *LIFETIME* warranty on doors

CONSTRUCTION FEATURES

- Heavy duty 430 Series stainless steel exterior, with attractive No. 4 finish
- Fully enclosed oven back
- Extra deep cooking compartment is porcelainized steel
- 2" insulation on six sides of cooking compartments
- Heavy duty, simultaneously-opening compartment doors, with large double pane tempered glass windows
- Powerful blower centered in back of compartment
- Compartment inspection lighting standard
- Chrome steel 10 or 11-position pan slides with five chrome plated wire racks provided

PERFORMANCE FEATURES

- 150 to 450°F operating temperature range
- Solid state temperature control accurate to ± 4°F
- Two speed fan with fan pulse capability
- Door interlock switch cuts power to fan
- Choice of four different control packages [See below]

CONTROL PACKAGE [Specify One]

Accu-Plus Controls [-AP]

- Simple knob-set time and temperature controls
- 1-hour timer with non-stop buzzer
- Pulse-fan switch
- HIGH-LOW speed fan switch
- Power-ON and inspection light switches

Selectronic II Controls [-S]

- Solid state temperature control with digital time/temperature display
- Heat loss compensation
- 10-hour countdown timer, with non-stop buzzer
- Automatic Cook-n-Hold switch
- Pulse-fan switch
- HIGH-LOW speed fan switch
- Power-ON and inspection light switches

Platinum Controls [-PT]

- Solid state, icon driven, one-touch programmable controls
- Up to 99 product programs, with multiple baking tiers
- Time, temperature, heat loss and adjustable shelf compensation
- Cook-n-Hold programming
- 2-speed fan & variable-rate pulse-fan control
- PC link programming
- Modem [Option]
- Power-ON and inspection light touch pads



Sheet No. LSP-C7 (rev. 01/12)

Electric, Full-Size/Extra-Deep Convection Oven

Model: ECOD-[AP/S/PT]1

INSTALLATION REQUIREMENTS

- (E) Site changeable dual voltage: 208V/240V, 1- or 3-Phase; or optional 480V, 3-phase electrical connection
- Installation under approved vent hood required. Contact local codes. [Power connection from rear. See below]

OPTIONS & ACCESSORIES

- 480V, 3-phase model
- 27" stainless steel angular legs
- 27" stainless steel tubular leg stands with under shelf & bullet feet
- 27" stainless steel tubular leg stands with under shelf, rack slides & bullet feet
- 27" stainless steel tubular leg stands with under shelf & casters
- 27" stainless steel tubular leg stands with under shelf, rack slides & casters
- Factory installed modem [Platinum/-PT models only]
- Factory recipe programming [Platinum/-PT models only]
- 3" stainless steel spacer
- Solid stainless steel doors, in lieu of doors with windows
- Extra wire pan racks [5 provided as std.]

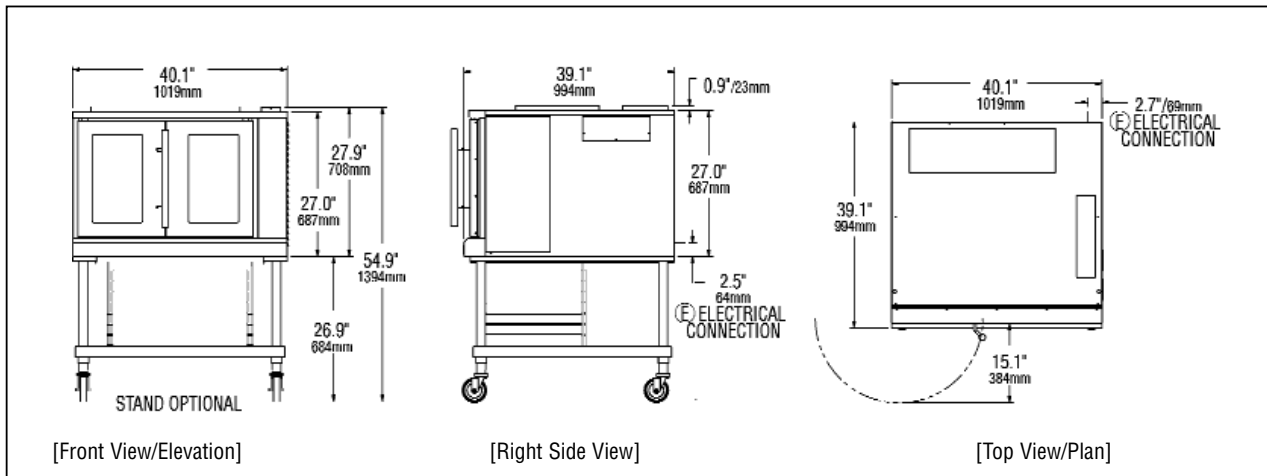

Model	Height x Width x Depth (without optional stand)	Clearance from combustible surface	Weight		Freight Class
			Actual	Shipping	
ECOD-[AP/S/PT]1	27.9" x 40.1" x 46.0" 708mm x 1019mm x 1168mm	Sides: 6" (153mm) Back: 6" (153mm) Floor: 6" (153mm)	460 lbs. 209 kg	500 lbs. 227 kg	70

Model	(E) Electrical Requirements			
	Voltage	Total kW	Phase	Amps/Line
ECOD-[AP/S/PT]1	208V/60Hz	11.7	1	56.1
	240V/60Hz	11.7	1	48.6
	480V/60Hz	11.7	1	24.3
	208V/60Hz	11.7	3	37.1
	240V/60Hz	11.7	3	28.8
	480V/60Hz	11.7	3	16.1

CAD SYMBOLS & PRICING



Due to continuous improvements, specifications subject to change without notice.



Sheet No. LSP-C7 (rev. 01/12)

LANG MANUFACTURING • 10 SUNNEN DR. ST. LOUIS, MO 63143
Phone: 314-678-6315 • FAX: 314-781-3636 • www.langworld.com