



Item No. _____

Project _____

Quantity _____

Gas, Charbroiler

Model: LRB-[24,36,48,60,72]



Model LRB-36

CONSTRUCTION FEATURES

- Stainless steel front, back & sides
- 20,000 BTU gas burners mounted every 6"
- Heavy-duty slanted, reversible cast iron cooking grates
- Stainless steel removable bottom drip tray
- 4" adjustable legs provided

PERFORMANCE FEATURES

- Angled grates ensure consistent broiling & no flare-ups
- Controls every 6" allows multi-product cooking or zoning
- Large capacity grease drawer needs emptying less often

CONTROL PACKAGE

- Gas control for every 6" of broiler surface

SIZING AND PERFORMANCE GUIDE

| Model/Width | Cook Surface [sq. inches] | Controls & Burners | BTU Input* |
|-------------|---------------------------|--------------------|------------|
| LRB-24 | 504 | 4 | 40,000 |
| LRB-36 | 756 | 6 | 60,000 |
| LRB-48 | 1008 | 8 | 80,000 |
| LRB-60 | 1260 | 10 | 100,000 |
| LRB-72 | 1512 | 12 | 120,000 |

* Natural and propane gas

SHORT/BID SPECIFICATION

Charbroiler shall be a **LANG Manufacturing Model LRB-__** [specify width: 24, 36, 48, 60 or 72 inch] unit with: 40,000 BTU/hr gas radiant heat burners every 6"; individual controls every 6"; heavy-duty slanted, reversible cast iron grates; large capacity drip pan; and all the features listed and the options/accessories checked:

STANDARD PRODUCT WARRANTY

One year, parts & labor



Sheet No. LSP-CB1 (rev. 06/07)

INSTALLATION REQUIREMENTS

- Specify: natural gas or propane gas: via 3/4" NPT connection
- Gas pressure regulator provided
- Specify elevation if project is over 2000 feet.
- Installation under approved vent hood required.
[All connections from rear. See below for location and delivery requirements]

OPTIONS & ACCESSORIES

- Stainless steel support stand with adjustable feet
- 5" compression-mount locking swivel casters for support stand

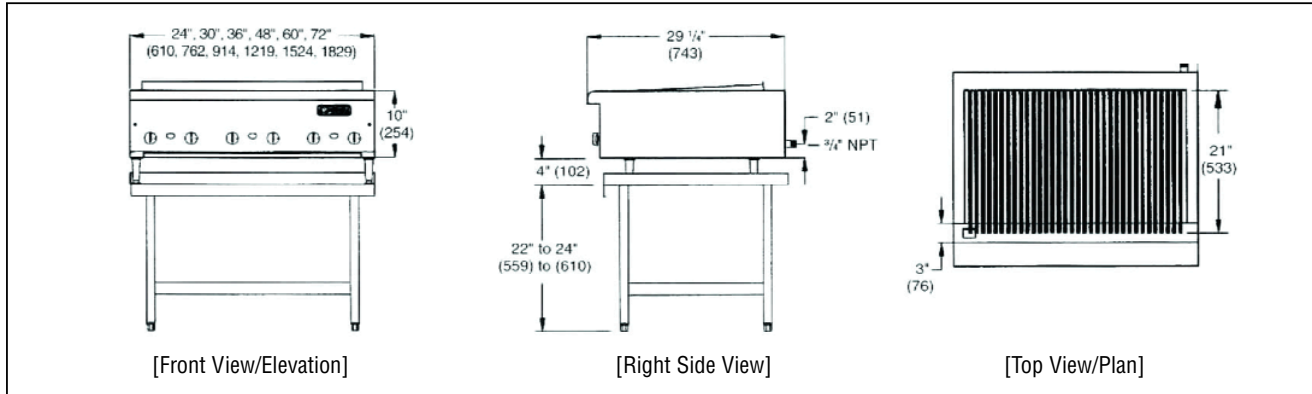

| Model | Height x Width x Depth (Not including legs) | Clearance from combustible surface* | Weight | | Freight Class |
|--------|--|--|--------------------|--------------------|------------------|
| | | | Actual | Shipping | |
| LRB-24 | 18.0" x 24.0" x 30.625" 457.2mm x 610mm x 777.9mm | Sides: 8" Back: 8" | 170 lbs. 77 kg | 200 lbs. 91 kg | 65 |
| LRB-36 | 18.0" x 36.0" x 30.625" 457.2mm x 914mm x 777.9mm | | 235 lbs. 107 kg | 265 lbs. 120 kg | 65 |
| LRB-48 | 18.0" x 48.0" x 30.625" 457.2mm x 1219mm x 777.9mm | | 315 lbs. 143 kg | 285 lbs. 130 kg | 65 |
| LRB-60 | 18.0" x 60.0" x 30.625" 457.2mm x 1524mm x 777.9mm | | 400 lbs. 182 kg | 430 lbs. 195 kg | 65 |
| LRB-72 | 118.0" x 72.0" x 30.625" 457.2mm x 1829mm x 777.9mm | | 490 lbs. 223 kg | 520 lbs. 236 kg | 65 |

* Noncombustible floor only.

| Model | Ⓒ Gas Requirement (3/4" NPT) |
|--------|---------------------------------|
| LRB-24 | 40,000 BTU/hr |
| LRB-36 | 60,000 BTU/hr |
| LRB-48 | 80,000 BTU/hr |
| LRB-60 | 100,000 BTU/hr |
| LRB-72 | 120,000 BTU/hr |

CAD SYMBOLS & PRICING



AutoQuotes

Due to continuous improvements, specifications subject to change without notice.



Sheet No. **LSP-CB1** (rev. 06/07)

LANG MANUFACTURING - A DIVISION OF STAR MANUFACTURING INT'L, INC. • 10 SUNNEN DR. ST. LOUIS, MO 63143
TOLL FREE: 800.264-7827 • FAX: 314-781-3636 • www.langworld.com